



iCoolXC[™]
ALL CLIMATE COMFORT[™]

Wall Mounted Air Source Heat Pump



iCool XC



Heat Pumps are Ready for the Cold

Ice Air iCool XC™ All Climate Comfort™ heat pumps are efficient, sustainable, units designed for cold climate energy efficiency. Providing the performance of a Variable Refrigerant Flow (VRF) system and the convenience of a packaged unit, the iCool XC Series combines sophisticated technology with a sleek, compact footprint that complements any décor.



The iCool XC Series complies with the NEEP Cold Climate Air Source Heat Pump (ccASHP) efficiency requirements. The Northeast Energy Efficiency Partnerships (NEEP) product listing identifies products best suited to electrify heating in cold climates.



The iCool XC Series produce superior energy savings, which is especially important to satisfy the NYC Law 97 and other laws throughout the U.S., as well as helping projects comply with green building rating systems such as LEED®.



Rebates, incentives, and tax credits may be available through state, federal, and local utility programs.

For additional information scan the code or visit: ice-air.com/rebates/

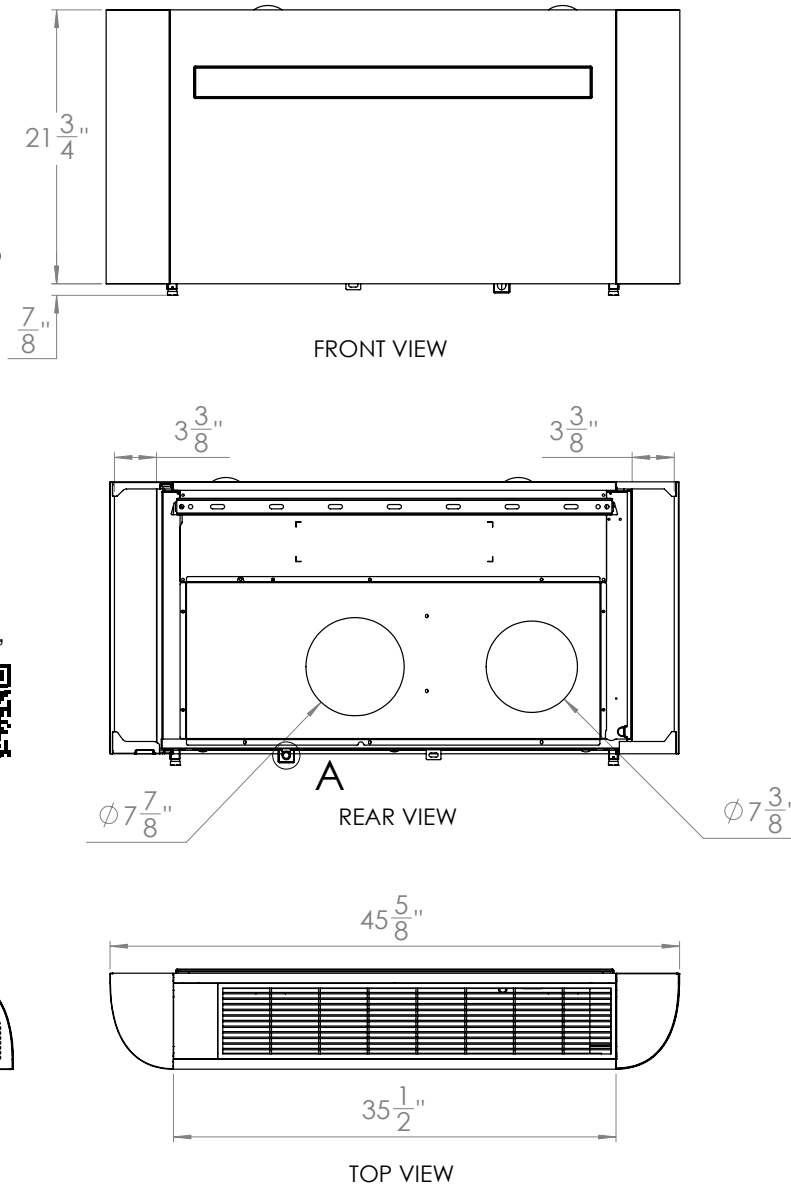
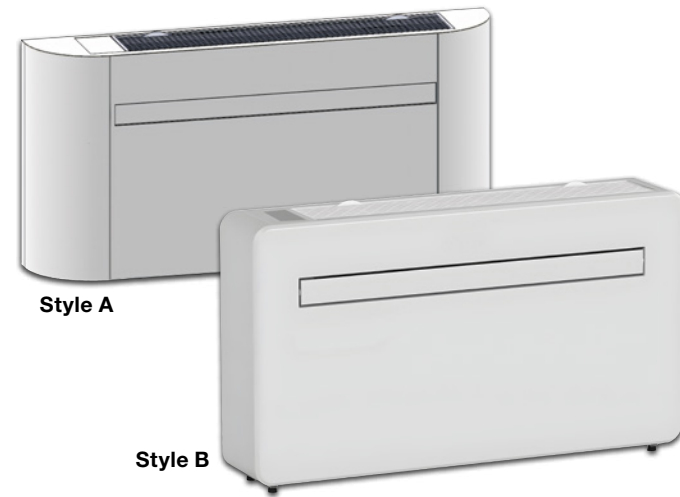

SERIES MODEL #	8RSXC09-DH
Cooling Capacity (Btu/h) ¹	7,800
Cooling Capacity Range (Btu/h)	3,000 - 15,000
SEER2 ¹	17.0
Heating Capacity (Btu/h) ²	8,000
Heating Capacity Range (Btu/h)	3,000 - 16,000
HSPF2 ²	8.0
Electric Heater (W)	1,000
Electric Heater (A)	4.8
Voltage	208
Current in Cooling Operation (Amps)	3.4
Power in Cooling Operation (Watts)	703
Current in Heating Operation (Amps)	3.2
Power in Heating Operation (Watts)	670
MCA	13.5
MOCP	15
Airflow (CFM)	310
Outside Air (CFM) ¹ (Optional)	40
Weight (lbs)	84
LOW AMBIENT PERFORMANCE	
Heating Capacity @ 22°F	6,600 + 3,400 Electric Heat
COP @ 22°F	2.44
Heating Capacity @ 13°F	6,100 + 3,400 Electric Heat
COP @ 13°F	2.00
Heating Capacity @ 5°F	5,600 + 3,400 Electric Heat
COP @ 5°F	1.79

SPECIFICATION NOTES:

1. Performance data according to CAC AHRI 210/240 standard.
2. Rated performances in cooling mode @ 80°F/67°F DB/WB Indoors and 95°F/75°F DB/WB Ambient
3. Rated performances in heating mode @ 70°F/60°F DB/WB Indoors and 47°F/43°F DB/WB Ambient
4. Electric Heater to run with heat pump when temperature falls below 23°F.

Compact and versatile, the iCool XC is engineered with advanced heat pump and inverter technology for optimal performance under a wide range of construction and climate conditions.

All electric, All Climate Comfort™ with Zero Emissions

On-demand Operation: Variable speed compressors modulate output based on room demand.

Compact Design: Sleek, modern footprint blends seamlessly with any décor. Slim 7.75 inch depth.

Furniture-Grade Finish: Chassis is concealed by a steel enclosure with a beautiful baked powder coat finish.

Enhanced Control Options: 4 function: Heat, Cool, Dehumidify and Fan comes standard with Habitat Wireless Thermostat with smart control capabilities.*

Features:

- Sustainable R-32 refrigerant
- Industry leading up to 25% greater efficiency
- Low noise operation
- Conceals plug and power cord within unit
- Just two 8 inch round wall openings needed for easy installation
- Wireless app control and 24-hour timer

* Smart app module must be purchased separately.



Electrified Product Family



* By making energy-saving upgrades today, you can give your building a head start on upcoming changes to city regulations such as NYC Law 97.

RSXC Series*

Cold Climate PTHPs give you the performance of a VRF system with the convenience of a PTAC. Using breakthrough cold climate technology allows Ice Air PTHPs to efficiently provide space heating down to -5°F and below.



iCool XC*

iCool XC heat pumps are compact, with advanced, two-stage dual heating capabilities (partial cold climate operation down to 23°F then supplemental electric heat resistance for increased output).



SPXC Series*

Cold Climate SPHPs are self-contained, concealed, ducted systems. This line of vertical packaged heat pumps serves multiple spaces through concealed ductwork to efficiently provide space heating to -5°F and below.



HPWH Series*

Air-Source Cold Climate Heat Pump Water Heaters capture the free energy in the environment and convert it to hot water. These units are certified to operate down to -13°F.



HPWH-SC Series*

Air-Source Cold Climate heat pump chiller heaters capture free energy in the environment to provide both hot and chilled water. These units are certified to operate down to -13°F.



VSHPGE Geothermal*

Ice Air's Geothermal WSHP is a versatile geothermal heat pump that is available in a range of sizes and configurations for convenient installation. Fully compatible with geothermal conditions, it provides an ideal solution for whisper quiet cooling and heating within a tight footprint.



W Series



S Series



H Series

New technologies like Variable Refrigerant Flow (VRF) are on the move. There is no denying the benefits of VRF any longer, and with Ice Air VRF, these benefits are delivered simply and effectively.



Ceiling Ducted DC Low Height



Mini 4-Way Cassette



4-Way Cassette



Wall Mounted



Ceiling Ducted High Static Pressure



Vertical Hi Rise

Other Products

FCU

Fan Coil Units



Horizontal Concealed



Horizontal Ultra Thin



Vertical Exposed



Vertical Concealed



Hi Rise

This simple and easy cooling and heating solution provides reliable performance, high efficiency, ease of operation, low cost, easy installation, quiet comfort and a variety of solution-based options.

HWCAC

Hybrid Water-Cooled Air Conditioners



Vertical Closet



Horizontal



Console



Vertical Stack

HWCACs provide hydronic heat without using the unit's compressor through an innovative system that combines high-efficiency cooling with a hot water coil.

WSHP

Water Source Heat Pumps



Vertical Closet



Horizontal



Console



Vertical Stack

WSHPs provide efficient room-by-room comfort. Units function independently and are piped to a central water loop.

PTAC

Packaged Terminal Air Conditioners

PTACs are designed for ultra-high efficiency and comply with LEED® criteria in a durable, user-friendly package. Available for new construction, retrofit and ExactFit™ replacement applications.



NEW! Ice Air CEU Webinar

Learn more about the role HVAC electrification plays in building decarbonization today at iceairceu.com



80 Hartford Avenue,
Mount Vernon, NY 10553
Tel: 877-ICE-AIR-1 (877-423-2471)
Main: 914-668-4700
Fax: 914-668-5643
email: sales@ice-air.com
www.ice-air.com